

SHOPSMITH SHAVINGS



The Editor's Workbench

Anybody with power hitched to his tools is likely to be so delighted with the time saved that he forgets there must be adequate time SPENT if the work is to be worth while. The difference between good and no-good may be the mere minutes or seconds needed for accurate measurement and proper tool set-up. And in things you make yourself, the test of craftsmanship is your knowing that "good enough" usually isn't.

Even simple sawing can be an example of how rushing the job can ruin the work. Almost any saw blade, especially when used on hardwoods, will chatter if the pass is made too fast. The teeth are designed to remove just so much wood and no more. When pushed beyond their capacity, the

teeth chatter; the vibration that occurs gouges the sides of the kerf. Too fast a feed also produces a rougher cut since fewer teeth pass over a given area of the wood. A moderate feed pressure—always slower than the saw will actually take—is best. It means a straighter, smoother cut with less power consumption.

Quite often, using the trifling extra time needed to produce the quality of craftsmanship we all should strive for, actually means less total time and money spent on the project. In the long run, you will avoid the mistakes that necessitate repeat operations and scrapped parts. Smitty's rule is, "Measure twice, cut once!" Old but everlastingly good advice.

New Book Welcomed by SHOPSMITH Owners

The enthusiasm with which the new book, **POWER TOOL WOODWORKING FOR EVERYONE**, has been received is difficult to describe without superlatives. Within one month of the sizeable first printing of 23,000 copies, a second printing was ordered, and we are now thinking about a third.

Praise for the book has come in from all sources—Editors, Writers, Industrial Arts Instructors—even Book Critics—all agree that this new book is a worthwhile addition to any craftsman's kit. Most gratifying is the response from SHOPSMITH owners who have purchased a copy. All are in accord with the statement that **POWER TOOL WOODWORKING FOR EVERYONE** is "the most important SHOPSMITH accessory."

All phases of woodworking, from simple cross-cutting and ripping on the table saw to special procedures like fluting and reeding on the lathe, are treated comprehensively and understandably in words and pictures. Here are the answers to the questions woodworkers have been asking—how to get full machine accuracy, the best and most accurate way to cut miters, tapers, tenons, spline grooves, compound angles, dovetails, and hundreds of other shapes and forms that are the very basis of woodworking craftsmanship.

The book describes and illustrates all the time-tested jigs that make woodworking easier, and that increase further the utility and flexibility of SHOPSMITH. Here is the one book tooled for the very machine you own and operate. Your SHOPSMITH dealer will be happy to let you browse through one, or you can order direct by using the enclosed business reply envelope. The photos at the right are typical of the 560 illustrations to be found in this big, 283-page woodworker's manual.

Coving Cut On The Table Saw

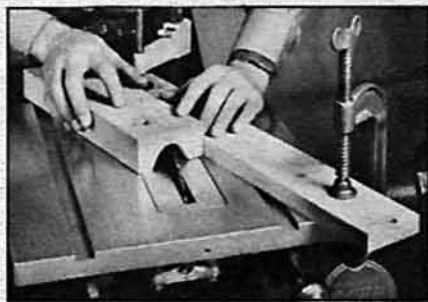

Fluting On Lathe

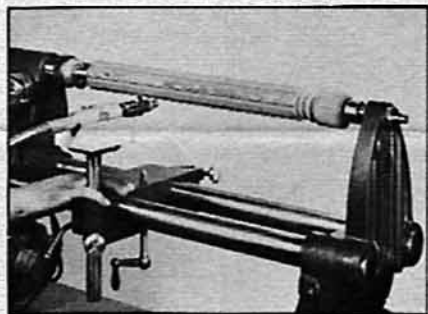

Jig Sawing Plastics



Jig Setup For Doweled Miter Joints

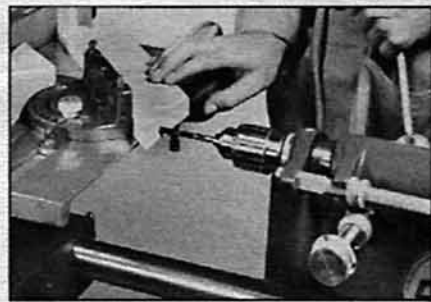

Pivot Sanding



Edge Shaping

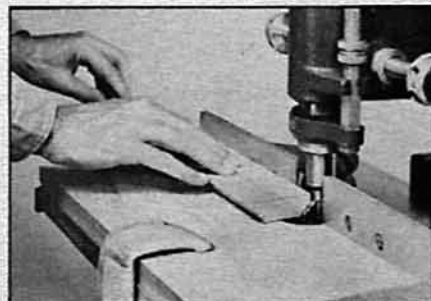

The Perennial Pusher Stick

We've seen craftsmen reach down to the floor for a scrap block when the need for a pusher arose. And we've seen elaborate collections of push sticks ranging from a notched stick made of polished black walnut to prosaic plywood stick sawed to the gentle curves of the female limb. But now, from Bob Bickling of Wilmington, Delaware, comes what we feel is a handsome and practical solution to the problem of pusher stick design. Bob feels, with justification, that the simple notched stick, regardless of embellishments, does not provide adequate protection for the hands. So he has designed a pusher that will straddle the rip fence and keep the hands far away from the blade. We've tried it and think you will like it too. It is a simple project and parts for it can probably be salvaged from the scrap box. The handle knob can be lathe turned with the stock mounted on a screw center, or a round, wooden door stop can be utilized. Dimensions are given in the drawing below. Hardwood is preferable. Assemble the parts with nails and glue and apply several coats of shellac to the finished project.

Pusher Stick In Use

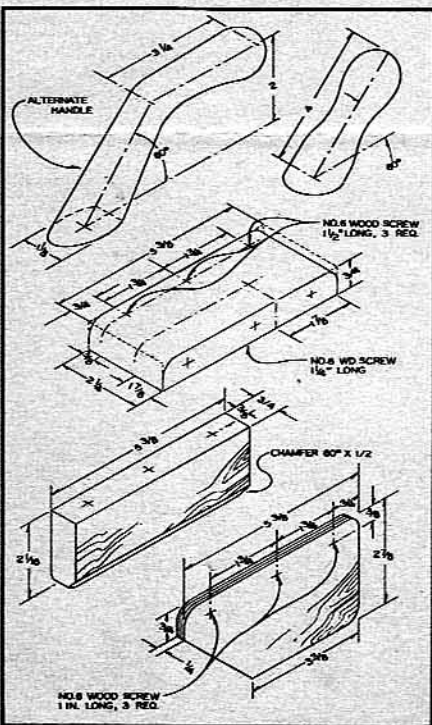

SHOPSMITH Tool Kit

All of the more than 150,000 SHOPSMITHS produced have used "socket head" screws to attach all components and accessories. Only two size "sockets" have been used (1/8" and 3/16") so that only two wrenches were required.

For technical reasons associated with the introduction of new SHOPSMITH accessories this fall it will be necessary to use 5/32" socket screws. It is important, therefore, that you have a 5/32" Allen wrench in your SHOPSMITH tool kit. Your SHOPSMITH dealer will carry this new 5/32" wrench in his store, but we wish to take every possible step to avoid the inconvenience to you of purchasing a new SHOPSMITH accessory, and then finding that you lack the wrench necessary for installation and adjustments. As a service to SHOPSMITH owners we, therefore, make the following offer:

A special length 5/32" Allen wrench will be sent by return mail if you enter your name and address on the gummed label enclosed with this issue of SHOPSMITH Shavings and mail it to Magna Engineering Corporation, Menlo Park, California, with 10c to cover cost of postage and handling.

This offer expires November 1, 1953.

We've Been Framed

Picture frames being a popular homeworkshop project, we thought you might be interested in how Ted Wright of Watertown, Mass., uses SHOPSMITH as a picture-frame clamping jig. As shown in the drawing below, Ted explains, "... the extension table is set about 1" higher than the saw table to back one side of the frame being glued. The rip fence is used to back the opposite side. A wood block is secured to the back of the saw table for the third side and the fourth side of the frame is backed up by the miter gauge which can be held in place with a C-clamp."

Sounds and looks fine to us. It is advisable to use waxed paper between the wood and SHOPSMITH to prevent excess glue from adhering to machine parts. With the pieces held in place by this method, it would be simple to drive nails through the mitered corners so that the frame can be removed and set aside to dry—a good idea for production runs. Ted goes on to say, "Provided that the four frame members are carefully mitered and within the limits of the table, this method has the advantage of insuring perfect squareness with ease in adjusting pressure. In fact, the method has worked so well that I have not had to supplement the glue with such fasteners as nails, screws, or dowels."

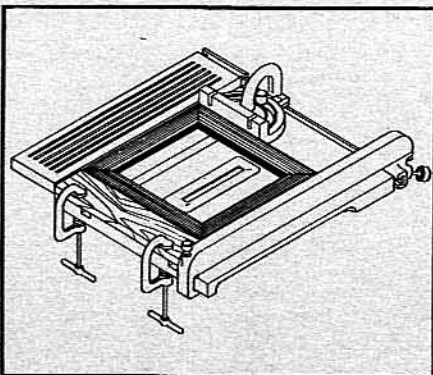

Duplicating Jig For Lathe Work

Tom Chapman, of San Francisco, California, thinks calipers are fine for gauging an occasional diameter on a lathe turning, but that some mechanical means of doing the job is called for when doing duplicate turnings. The clever jig he designed to fill the need is shown in use in the photograph below. Basically, it is no more than a vertical post which is locked in the rear hole in the table carriage. This holds a horizontal rod support for adjustable leaves which gauge the depth of cut.

The workpiece is first turned to full round. The leaves are then spaced along the horizontal rod relative to distance between sizing cuts. The leaves, which are set for depth of cut, ride the groove formed by the parting tool—the lathe chisel used to cut to the depth required. Full depth of cut is indicated when the leaf falls down. When the initial adjustment is made, the turning and the leaves must have a common horizontal center line. Follow the drawing below when making the jig. A hardwood such as maple or birch should be used.

Jig In Use

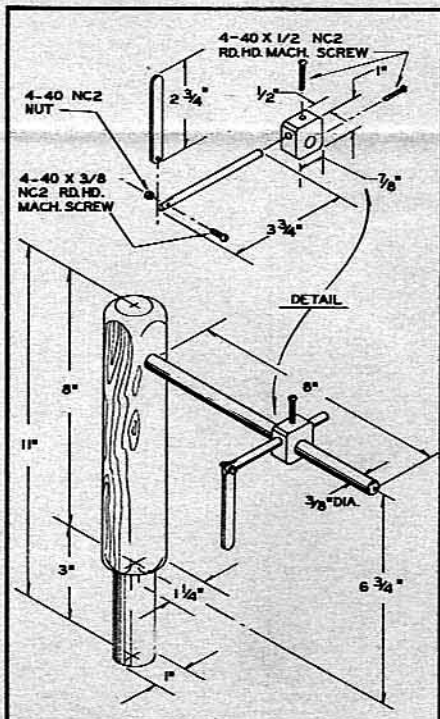
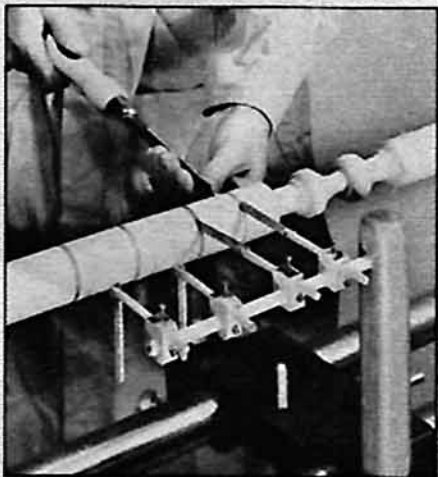



about SHOPSMITH ACCESSORIES

JIGSAWS ARE AVAILABLE AGAIN! Thanks to increased supplies of critical materials, SHOPSMITH dealers are now adequately stocked with the popular SHOPSMITH JIGSAW. The JIGSAW, if you don't already know, utilizes the powerful motor, the bench and saw table of SHOPSMITH. It can be mounted, ready for use, in seconds. It cuts to the center of a 36" panel, and has unlimited cutting capacity as a saber saw. Now you can make those fancy, scrolled cornices and attractive, pierced bric-a-brac shelves. Hardwoods, softwoods, plywoods, plastics, metals and many other materials are easily cut with the JIGSAW. And it's a wonderful "starter" tool for the youngsters too! **See it at your dealers.**

SHOPSMITH OWNERS have been asking for a molding head for such a long time that we felt compelled to add this practical and useful table saw accessory to the line. Now you can use the table saw to do edge and surface molding operations as well as many other jobs difficult to do otherwise. The MAGNA MOLDER mounts directly on the SHOPSMITH spindle, or on any 5/8" arbor. There is a "library" of seventeen sets of molding knives selected on a "most used" basis. The MAGNA MOLDER package includes a four-page instruction sheet that shows you how to get the most out of this valuable new accessory. **See it at your dealers.**

HOLD DOWN NEWS will be made when the UNIVERSAL HOLD DOWN set hits the stores (which should be about the time you receive this issue of SHAVINGS). This accessory is a must for all people interested in power tool operation. It increases accuracy, safety and convenience on many operations. Products now on the market are "single-purpose"—limited in use to the accessory or tool for which they were designed, such as the miter gauge or shaper. The UNIVERSAL HOLD DOWN, like SHOPSMITH, is designed for maximum utility so it can be used on the miter gauge, on the rip fence, the shaper fence, or clamped to any side of the saw table in vertical or horizontal position.

Use it for crosscutting, mitering, molding-head cuts, shaping operations, for holding odd-shaped pieces. Actually, the HOLD DOWN supplies a second pair of hands to help you do a better, safer job! Package includes a four-page instruction sheet to help you make the most of the set. **See it at your dealers.**

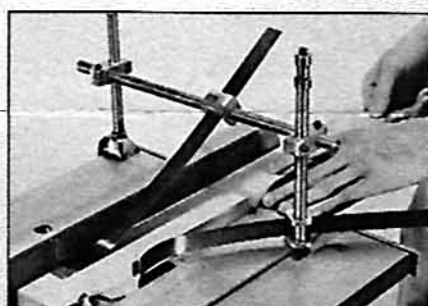
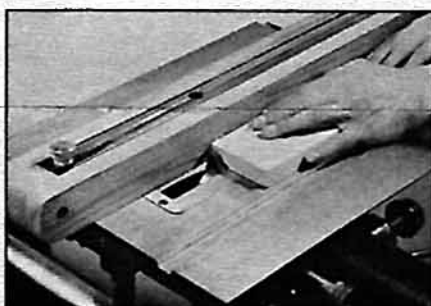
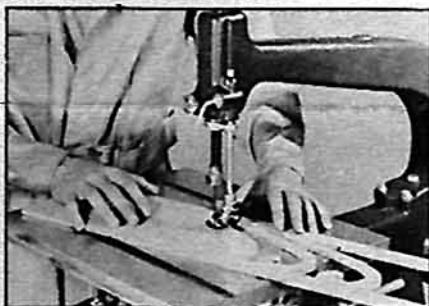

Attention "Rockhounds"!

You SHOPSMITH OWNERS who might like to try your hand at the increasingly popular hobby of lapidary work, can pick up some very helpful ideas from the information sent in by George Sabin of Monroe, Washington. George tells us that he has been cutting, grinding, polishing and drilling gem stones for two years with SHOPSMITH as his only tool. He uses an 8" diamond saw, silicon carbide grinding wheels and sanding discs, and a hard, felt buff.

The sketches below indicate some of the methods he uses. Cutting is done with the diamond saw and saw table situated as in disc sanding. The rock is held between wooden boards which are clamped to the miter gauge as shown. Slabs as fine as 1/16" thick are cut very accurately with this setup. A metal hood is used over the saw while a two-gallon oil can—cut in half, lengthwise—holds a lubricant composed of equal parts of kerosene and lubricating oil. Block this up on the ways so that the rim of the saw runs in the bath.

In the grinding operation, George sets SHOPSMITH in vertical position with the wheel running below the top level of a pan 6" or 8" high. Some provision must be made for a small stream of water which must be played on the grinding wheel constantly to avoid overheating and chipping of the rock. For the water pan, George suggests an Alemite Grease drum with a 2" plywood rim on the top edge. Sanding is done with the proper grit paper secured to a metal or wood disc with a rubber or felt cushion between the paper and the disc. The polishing is done with the hard felt buff. A speed changer is almost essential for this type of work.

Extreme caution should always be observed to avoid damaging grit on the tubular ways. **WEAR GOGGLES,** and always—especially when cutting—**FEED SLOWLY!** George cautions beginners to first study books on gem cutting, care of the diamond saw, proper grinding wheels and sanding discs and their care.

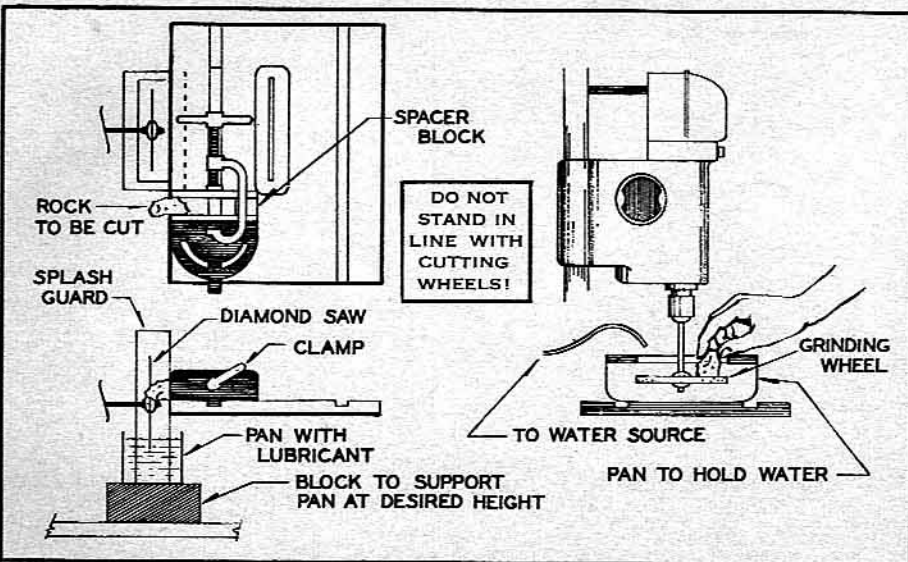

Meet SHOPSMITH'S Big Brother

In February, 1952, MAGNA ENGINEERING CORPORATION introduced a revolutionary new industrial drilling machine called MAGNA DRILL. Unlike any other industrial drilling equipment, MAGNA DRILL consists of one-horsepower drill heads, with the drive through the ground steel tube that forms the throat. This gives MAGNA DRILL a throat adjustable from 6 1/2" to 14", (drill to the center of a 28" circle), and complete angular freedom of 360 degrees in two planes.

A supporting system of ground steel columns, column bases and modular tables, permits mounting the heads at any angle, in any plane, for simultaneously drilling a group of holes. There is a package gear power feed that merely bolts on the headstock face and has an electrical solenoid engagement. To make a fairly complicated story short, this permits any user, for the first time, to set up equipment for simultaneous multi-plane drilling quickly and easily.

As any one production run (and it need not be a large quantity) is completed, MAGNA DRILL can be quickly changed to another setup for an entirely different part. In the photograph below, three MAGNA DRILL heads are set up for simultaneous drilling of the holes in the SHOPSMITH rip-fence base casting. Eighteen seconds is all the time required for the three operations involved, and accuracy is greater than with conventional methods. MAGNA DRILLS have already been installed in leading industrial plants. The new machine has proved to be just as revolutionary in conception and practical in application for the industrial field, as SHOPSMITH has proved to be in the homeworkshop.

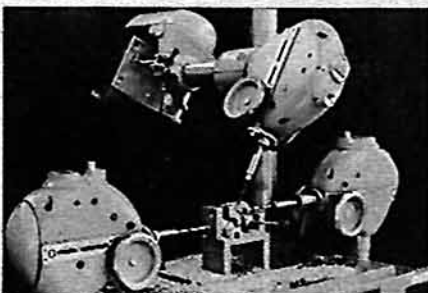



Shop Chips and Chats

Military officers who are SHOPSMTIH enthusiasts and, apparently, experts in logistics, have devised a system whereby they can leave their SHOPSMTIH and still have it. Here is how it works. An officer in Washington will ask the officer he is relieving overseas to locate someone with a SHOPSMTIH who is about to return. The two then merely trade, and save the trouble of crating and the use of that much of their weight allowance. Another item of interest to military personnel, and all people who must make frequent moves, is the SHOPSMTIH BENCH-CRATE. This is a strong SHOPSMTIH bench which is easily converted to a sturdy shipping crate. It is not difficult to make, and plans are available through your SHOPSMTIH dealer.

The depth of cut scale which is stamped on the sides of the rip fence may also be used to adjust table height when doing horizontal drilling. Bring the fence close to the drill, which is held in the chuck, and adjust the table up or down until the drill point is opposite the graduation needed. When setting the table height, be sure the rip fence is locked both front and rear.

The editors of MECHANIX ILLUSTRATED inform us that Golden Hammer awards will be made each month to eight readers submitting the best snapshot of some workshop project that they have completed themselves. The award is a regular 16-ounce claw hammer, but before the handle is fitted the forged steel head is coated, first with copper, and then with a heavy plating of real gold. In addition to the Golden Hammer, each winner receives an 11 x 14 Workbench Award Certificate attesting to his expert craftsmanship. Entries should be mailed to Golden Hammer Awards, MECHANIX ILLUSTRATED, 67 West 44th Street, New York 36, N.Y. R. G. Lurain (Prairie Village, Kansas) won with a SHOPSMTIH workshop photo. Who will be next?

Recently, 10,000 SHOPSMTIH owners whose names were selected on a random basis received questionnaires soliciting comments on (y)our favorite power tool. We are sincerely grateful to all owners who participated, and wish to express our thanks for the many creative and constructive suggestions. All comments were carefully read and evaluated, and will be taken into consideration in future planning. We're sorry we did not contact ALL owners but—don't forget—your letters and notes and suggestions are always welcome. Please keep them coming.

From Pretoria, Transvaal, in the Union of South Africa, Sidney J. Saks sends a wise little suggestion. "When using the drum sander in conjunction with the saw table for thickness sanding—after setting the table height for sanding one surface of the wood, instead of making a minute adjustment to set the table up enough for the drum to contact the second side of the wood, merely place a sheet of smooth paper between

the wood and the table, and feed the work through as before. The adjustment may be varied by the number of sheets of paper used."

Vernon Youngs, shop instructor at Columbus High School in Columbus, North Dakota, informs us of a lathe procedure he suggests in the classroom. "In turning face plate jobs on the SHOPSMTIH lathe, I sometimes run the wood into the tailstock to prevent any chance of the wood on the face plate from breaking loose. An entire bowl can be turned this way with the exception of a thin piece touching the tailstock. The operation of the quill feed and the construction of the tool rest on SHOPSMTIH make this easy to do." We agree and would like to point out that this procedure is especially applicable on large turnings in heavy woods.

From Hampton, Iowa, Ed Lauterbach writes in to tell us how he cuts through glass tubing on SHOPSMTIH. He made a wood chuck for his lathe face plate and turned a cavity in it that was a tight fit for the glass tubing. He mixed number two grinding compound (available from optical supply company) with water. Then he dipped a one-foot length of radio antenna (stranded) wire in the compound mix and held it with light pressure against the tube while it turned at slow speed (#1 pulley). The wire, of course, should be dipped in the mix frequently. We think a back-up block mounted on the live center in the tailstock will provide needed additional support. Other than that we have nothing to add except two caution notes: Protect tubular ways from grit and do not hasten the job—the tube might over-heat and break.

Large panels which have irregular ends, and cannot be held against the rip fence, are easily squared off on SHOPSMTIH by the following procedure: lock headstock and table at the left end of the tubes, and mount the extension table on the tailstock. Then nail or clamp a straight board to the underside of the panel, and use this to ride against the right hand edge of the saw table as the pass is being made. Position of the guide board is determined by the amount of material that must be cut off.

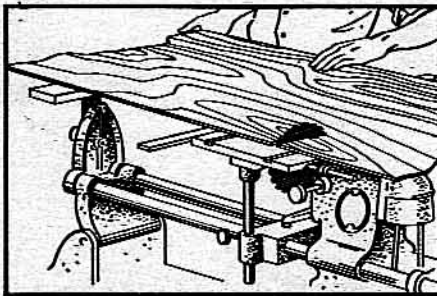

SHOPSMITH Workshop Layout Contest

Do you have the ideal SHOPSMTIH workshop? If you think you do, here is an opportunity to share your ideas with other craftsmen and perhaps earn a prize doing so. We want to know about your shop. Is it in a garage? Basement? Attic? How is it set up? How large is it? How does SHOPSMTIH make it possible for you to obtain maximum utility from the space you have available? Is your SHOPSMTIH permanently situated, or do you "caster it out" when some weekend or evening carpentry is in order? By answering these questions and giving us some further information, you may win one of six prizes consisting of a SHOPSMTIH accessory plus a U. S. Savings Bond. Here are the rules:

- 1... To be eligible for a prize you must submit a glossy photograph (preferably 8" x 10") of your SHOPSMTIH shop; a floor plan of the shop (this need not be artistic, but merely to indicate size and arrangement); and about 250 words of typewritten copy telling us about your shop and its functions.
- 2... Address entries to:
SHOPSMITH Workshop Layout Contest
Magna Engineering Corporation
Menlo Park, California
- 3... Closing date of the contest is November 1, 1953. Entries received after this date cannot be considered.
- 4... Employees of Magna Engineering Corporation, its affiliates and advertising agencies are not eligible.
- 5... Winners will be notified by mail during the month following the closing date of the contest. Winning entries become the property of Magna Engineering Corporation, and will be published in future issues of SHOPSMTIH SHAVINGS.
- 6... Entries cannot be returned unless accompanied by a stamped, self-addressed, return envelope.

PRIZES

- 1st prize—SHOPSMITH JIGSAW plus \$100.00 U. S. Savings Bond
- 2nd prize—SHOPSMITH JIGSAW plus \$50.00 U. S. Savings Bond
- 3rd prize—MAGNA DADO plus \$25.00 U. S. Savings Bond
- 4th prize—MAGNA DADO plus \$25.00 U. S. Savings Bond
- 5th prize—SHAPER FENCE plus \$25.00 U. S. Savings Bond
- 6th prize—SPEED CHANGER plus \$25.00 U. S. Savings Bond

If you are a winner and already own the accessory offered, you may choose an equivalent amount of tools from our accessory catalog.

GOOD LUCK!

Magna Engineering Corporation

MENLO PARK · CALIFORNIA

PLANTS IN BERKELEY AND CLEVELAND

Copyright 1953
Magna Engineering Corp.